

This article was downloaded by:

On: 25 January 2011

Access details: *Access Details: Free Access*

Publisher *Taylor & Francis*

Informa Ltd Registered in England and Wales Registered Number: 1072954 Registered office: Mortimer House, 37-41 Mortimer Street, London W1T 3JH, UK



Journal of Sulfur Chemistry

Publication details, including instructions for authors and subscription information:

<http://www.informaworld.com/smpp/title~content=t713926081>

Thiocarbonyl compounds from β -substituted vinylald- and -ketimmonium derivatives

Lyudmila Timokhina^a; Mikhail Voronkov^a

^a A. E. Favorsky Irkutsk Institute of Chemistry, Siberian Division Russian Academy of Sciences, Russia

To cite this Article Timokhina, Lyudmila and Voronkov, Mikhail(2004) 'Thiocarbonyl compounds from β -substituted vinylald- and -ketimmonium derivatives', Journal of Sulfur Chemistry, 25: 2, 213 – 239

To link to this Article: DOI: 10.1080/17415990410001697114

URL: <http://dx.doi.org/10.1080/17415990410001697114>

PLEASE SCROLL DOWN FOR ARTICLE

Full terms and conditions of use: <http://www.informaworld.com/terms-and-conditions-of-access.pdf>

This article may be used for research, teaching and private study purposes. Any substantial or systematic reproduction, re-distribution, re-selling, loan or sub-licensing, systematic supply or distribution in any form to anyone is expressly forbidden.

The publisher does not give any warranty express or implied or make any representation that the contents will be complete or accurate or up to date. The accuracy of any instructions, formulae and drug doses should be independently verified with primary sources. The publisher shall not be liable for any loss, actions, claims, proceedings, demand or costs or damages whatsoever or howsoever caused arising directly or indirectly in connection with or arising out of the use of this material.

REVIEW

Thiocarbonyl compounds from β -substituted vinylald- and -ketimmonium derivatives

LYUDMILA TIMOKHINA* and MIKHAIL VORONKOV

A. E. Favorsky Irkutsk Institute of Chemistry,
Siberian Division Russian Academy of Sciences,
1 Favorsky, Irkutsk, 664033, Russia

(Received 24 July 2003; In final form 1 March 2004)

Results on the synthesis of thiocarbonyl compounds based on the reactions of conjugated unsaturated immonium salts with *S*-nucleophiles are summarized, and the physical and chemical properties as well as the synthetic potential of forming α,β -unsaturated thioaldehydes and thioketones are considered.

Keywords: Thioaldehydes; Thioketones; β -Substituted unsaturated immonium salts; Hydrothiolysis

1. Introduction

The development of methods for the synthesis and investigation of transformations of carbonyl thiocarbonyl compounds have proved to be an important component of the chemistry of organic sulfur compounds. The synthetic route to thiocarbonyl compounds, described in the present review, is based on the hydrothiolysis of the $C=N^+$ bond in β -substituted vinylald- and -ketimmonium derivatives $Y-C=C-C=N^+R^1R^2 \cdot X^-$ [$Y = RO, RS, Hal, Z=C-C=C-S$ ($Z = O, S, N^+R^3R^4 \cdot X^-$)] and can be effected under specially chosen conditions. In the same way it was possible to synthesize new or rarely accessible α,β -unsaturated thioaldehydes, thioketones with rare atom groupings, $RO-C=C-C=S, RS-C=C-C=S, Hal-C=C-C=S$, bis(α,β -unsaturated) dithioketones $S=C-C=C-S-C=C-C=S$, etc. Apart from theoretical and synthetic interest, these compounds are rather promising in practical chemistry as synthons, organic metals, solar energy transformers, drugs and other biologically active substances.

β -Heterofunctional α,β -unsaturated immonium salts have high and diverse reactivity. Information from the reactions of nucleophilic substitution in salts of this kind provides evidence for the ambident character of the $Y-C=C-C=N^+$ ($Y = HO, RO, HS, RS, Hal$) cation [1, 2]. The interaction of the charged nucleophiles with the $Y-C=C-C=N^+$ group can lead to

* Corresponding author. E-mail: tim@irioc.irk.ru

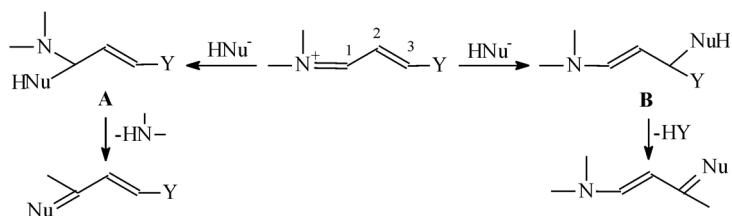

SCHEME 1

two intermediate adducts (**A** or **B**) depending on the direction of attack (on atoms C1 or C3) (scheme 1).

The results of nucleophilic substitution on this type of salts should adhere to both charge and orbital control and, correspondingly, the reaction direction should depend on the “soft-hard” properties of the nucleophile and the two electrophilic centers in the substrate. Moreover, in each case, due account should be taken concerning (i) the influence of steric and electronic effects of substituents on $Y-C(R')=C(R'')-C(R''')=N^+R^1R^2$ fragment, (ii) acid–base properties of the medium, (iii) the effects of solvation, (iv) reaction temperature and (v) time. Examples of hydrolysis, aminolysis and thiolysis of immonium salts in which the reaction center is either the C1 or C3 atom are known, and sometimes both electrophilic centers of the molecule are involved [2].

The mechanism of the thiolysis of β -alkoxy- or β -chlorovinylmethineimmonium salts is unequivocally interpreted as that involving the C3 atom as an initial center of attack by a sulfhydryl anion. This process has been widely used for the synthesis of various enaminothioketones [1].

A systematic study on the thiolysis of β -heterosubstituted α,β -unsaturated immonium salts has made it possible to establish the direction of nucleophilic attack on the above salts and helped to develop a general approach to the synthesis of previously unknown thiocarbonyl compounds [3–8].

Immonium salts are readily available. *N*-(3-Chloro-3-phenylprop-2-en-1-ylidene)-*N,N*-dimethylimmonium perchlorate has been prepared using the Vilsmeier reaction by the action of DMF–POCl₃ on acetophenone [1]. The same method was employed for the synthesis of indolylmethylenimmonium perchlorates from indole and substituted indoles [9]. β -Alkoxy- and β -alkyl-substituted salts of the cyclohexene and indene series were obtained by the alkylation of corresponding enaminothioketones or enaminothioketones [4, 6, 7].

2. Immonium salts in the synthesis of thioaldehydes

2.1 Hydrothiolysis of 3-alkylthio(chloro)prop-2-en-1-ylideneimmonium salts: an approach to the synthesis of β -hetero-substituted α,β -unsaturated aliphatic thioaldehydes

In the reaction of 3-substituted propenylideneimmonium salts with “soft” nucleophiles, the C₃-hetero-substituent bond is reported to be attacked [1]. However, in the reaction of *N*-(3-chloro-3-phenylprop-2-en-1-ylidene)-*N,N*-dimethylimmonium perchlorate (**1**) [10] or *N*-(3-methylthio-3-phenylprop-2-en-1-ylidene)-*N,N*-dimethylimmonium iodide (**6**) [11] with hydrogen sulfide in anhydrous DMF at -60°C , the *S*-nucleophile attack is directed onto the carbiminium group $C=N^+$, yielding the corresponding thials *in situ*.

However, it has not been possible to either isolate 3-chloro-3-phenyl-2-propenethial (**2**) in the monomer form or identify it as a trimer, oligomer or a cycloadduct [10]. This may be because the chloropropenethial **2**, which was initially formed by hydrothiolysis of salt **1**, reacts rapidly with hydrogen sulfide at the C–Cl bond to give mercaptopropenethial **3**. Being a thiol, the latter readily adds *in situ* to the C=C bond of the chlorothial **2**. The sulfide

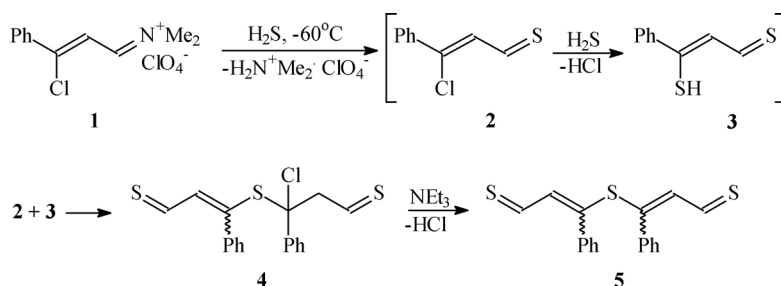

SCHEME 2

(4) formed in this case (61%) loses HCl through the agency of triethylamine and transforms into bis(3-thio-1-phenylpropenyl) sulfide (5) (scheme 2). The ¹H NMR spectrum (CDCl₃, δ, ppm) of 1,7-dithial 5 [7.77 m (12H, 2C₆H₅, 2HC=), 9.00 s and 9.06 s (2H, 2CH=S)] shows the presence of two signals in the region of thioaldehyde group resonance. This provides evidence that compound 5 is a mixture of geometric isomers (2.5:1 ratio).

3-Methylthio-3-phenyl-2-propenethial (7) formed during hydrothiolysis of *N*-(3-methylthio-3-phenylprop-2-en-1-ylidene)-*N,N*-dimethyliminium iodide (6) was isolated as a cream-colored stable trimer 8 (scheme 3) [11].

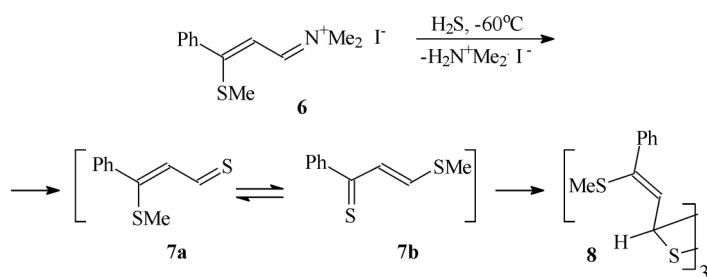

SCHEME 3

The established site of the hydrothiolysis of vinylaldiminium salts at low temperature has provided access to the synthesis of β-hetero-substituted α,β-unsaturated aliphatic thioaldehydes.

Thioaldehydes are prone to intra- and intermolecular transformations [12]. The mechanism of these reactions is poorly understood, mainly due to difficulties in experimental kinetic studies. Therefore quantum-chemical considerations of this problem look rather promising.

The conformational mobility and possible intramolecular rearrangements of 5 have been studied by the AM1 semi-empirical methods [13]. The potential stationary states that can retain their individuality in the reaction medium were divided into three groups. The possibility of rotamer transition from one group to another is unlikely due to high activation parameters of the process (60–130 kcal mol⁻¹). A group having the most stable stationary states has been identified to contain eight rotamers (figure 1).

Among the conformers obtained are some with an electronic structure and geometry favorable for the formation of thiirane cycles. For open rotational forms of the dithial 5, spontaneous trimerization can provide a competing route with respect to the reaction channel for thiirane structure formation. Rotamers most promising from the viewpoint of trimerization have also been recognized. The relative stabilities of trimers have been compared and of these the most stable structure has been offered (figure 2) [13].

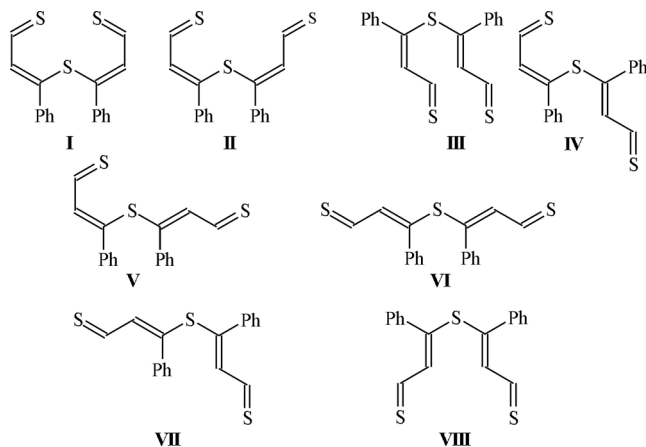

Figure 1.

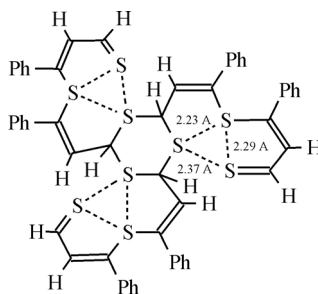
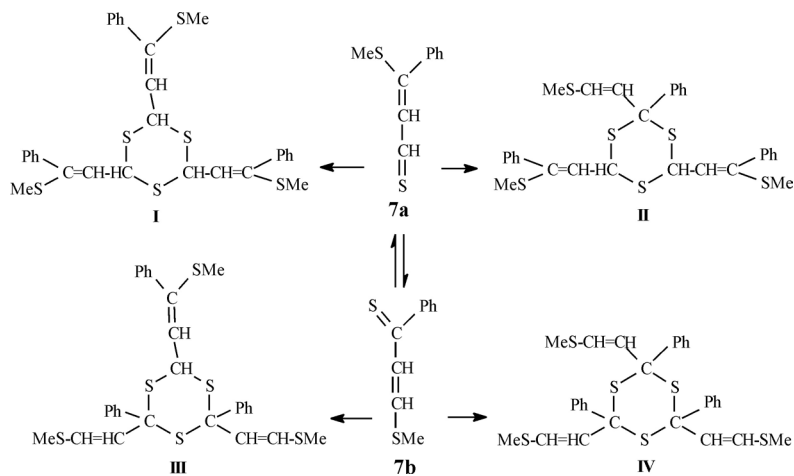

Figure 2.

Quantum-chemical calculations of possible structural transformations of **7** have been carried out [14]. Semi-empirical AM1 and PM3 methods have been used to show the possible formation of **7a** and its tautomer, 3-methylthio-3-phenylprop-2-ene-1-thione (**7b**). In polar media these products can be trimerized to structures of four types. The trimer type depends on the displacement of equilibrium in the thial **7a** \rightleftharpoons thione **7b** mixture (scheme 4).



SCHEME 4

Each of the four trimer types has been characterized by the presence of three six-membered nearly planar pseudo-chelate cycles. The possibility of preparing 1,2-dithiolane derivatives, the main fragment of biologically essential lipoic acid, from the reaction products in non-polar solvents (scheme 5) has been carefully considered [14].

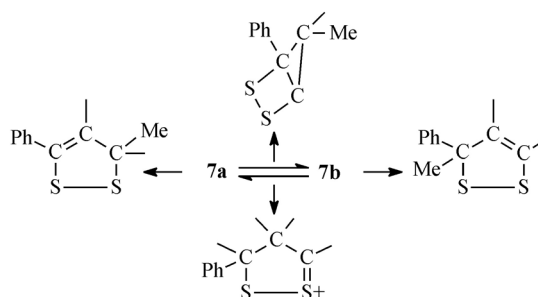

SCHEME 5

Thioaldehydes are a unique class of sulfur organic compounds. They were long thought to be extremely unstable and therefore remained poorly understood. However, interest in their synthetic and applied chemistry has greatly increased due to studies carried out in different countries [12, 15, 16].

2.2 3-Thioformylindole and its derivatives

Synthesis. In 1966, thioformyl indole derivatives were represented by only 3-thioformyl-1,2-dimethylindole **10b** [17]. It was prepared by treatment of the corresponding Vilsmeier salt (**9b**) with aqueous sodium hydrosulfide. Under these conditions *N*-[(3-indolyl)methylene]-*N,N*-dimethylimmonium perchlorate (**9a**) is hydrolyzed to 3-formylindole [18].

Thials **10a, c–e** have been synthesized by the action of anhydrous sodium hydrosulfide or hydrogen sulfide on the corresponding methineimmonium salts **9** in DMSO or DMF in the temperature range -20 to 20 °C (scheme 6) [9, 18].

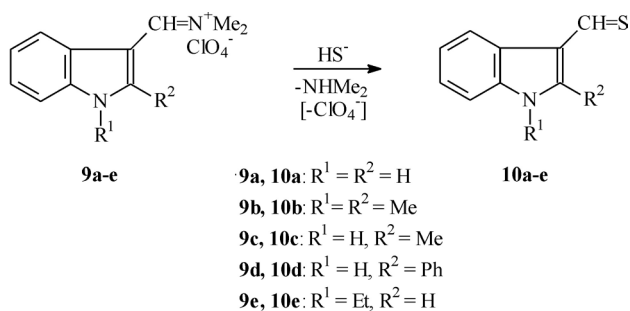

SCHEME 6

Thioaldehydes **10a, c, d**, which do not bear a substituent on the nitrogen atom, have been isolated as crystal-solvates (**Ks**) with DMSO or DMF (3:1) in $\sim 90\%$ yield. On dissolution they readily dissociate to form the monomer of the corresponding thioaldehyde. Compounds **10b** and **10e**, containing an alkyl group at the nitrogen atom, do not form complexes with the above solvents. Depending on the reaction temperature, 3-thioformyl-1-ethylindole **10e** was isolated either as a monomer or as its mixture with the trimer. The transformation of perchlorate **9a** into 3-thioformylindole **10a** was followed by polarography and spectrophotometry (table 1) [9].

Table 1. Polarographic characteristics and data of electron spectra of compounds **9a**, **10a**, **Ks**.

Compound	Electron spectrum, $\lambda(\log \varepsilon)$	Polarographic reduction in DMF, $E_{1/2}(i/c)$
9a	264 (4.01)	-1.520 (3.38)
	275 (4.02)	-2.530 (3.50)
	281 (3.75)	
	342 (4.25)	
10a	275 (4.02)	-0.925 (3.40)
	283 (3.97)	-1.700 (5.00)
	374 (4.40)	-2.480 (8.17)
	512 (1.56)	
Ks ^a	275 (3.95)	-1.650 (2.09)
	277.8 (3.90)	-2.530 (2.12)
	375 (4.34)	

^a [3 **10a** · Me₂NCHO].

The ¹H NMR spectra (DMSO-d₆, DMF-d₇) of thioformylindoles **10a–e** show the signal of thioaldehyde group proton in the region 11.29–11.41 ppm; in the ¹³C NMR spectrum of 3-thioformylindole (**10a**) the thioaldehyde group carbon resonates at 185.17 ppm. The reaction of thioformylindoles **10a, c** with 2,4-dinitrophenylhydrazine in DMF affords the corresponding hydrazones [9]. The electronic spectra of 3-thioformylindole (**10a**) and substituted 3-thioformylindoles **10b–e** have been studied both experimentally (acetonitrile and dioxane as solvents) and theoretically (CNDO/S in AM1 approximation) [19].

The absorption observed in the near-ultraviolet region is caused by electron transitions of various types and intensities. The two most long wave-length signals [for example, for **10b** λ_{\max} nm (lg ε) (MeCN): 384 (4.44), 285 (3.88)] generally represent the molecular and practically uniconfigurational transitions ($\pi \rightarrow \pi^*$). They exhibit mutually perpendicular polarization and clearly express the character of charge-transfer transitions.

The charge-transfer depends weakly on substituents at the nitrogen atom and is substantially enhanced with increasing electron-donor properties of substituents at C2 of the indole cycle.

Reaction with benzyldimethylselenoniomethanide. Using 3-thioformylindole (**10a**) and its derivatives **10b, c** as examples, the reaction of thioaldehydes with selenium monoketoylide **11** has been studied [20]. The latter is generated *in situ* by deprotonation of dimethylphenacylselenonium bromide [(Me₂Se⁺CH₂COPh)Br⁻] in an aqueous solution of caustic soda. The interaction of reagents **10** and **11** readily proceeds in DMF at -20 to 0 °C in an inert gas atmosphere (scheme 7).

The addition of **11** as a C-nucleophile to the C=S bond would be expected to lead to the corresponding thiirane derivatives **12** [21]. However, with unsubstituted 3-thioformylindole (**10a**), isomers **13** and **14** have been isolated from the reaction mixture (3:1 ratio, total yield 65%) [20]. The ¹H NMR spectra (CDCl₃, δ , ppm) show signals at 3.96 s (2H, CH₂) (for **13**), 4.32 s (2H, CH₂) (for **14**), 7.08–8.35 m (1H, NH and 10H, H arom.). ¹³C NMR spectra (CDCl₃, δ , ppm) exhibit signals at 38.01 (CH₂) (for **13**), 39.05 (CH₂) (for **14**).

The products of the reaction of 3-thioformyl-1,2-dimethylindole (**10b**) turned out to be the corresponding mercaptoethenes **15b** and **16b** (total yield 64%), whereas those of 3-thioformyl-2-methylindole (**10c**) are mainly represented by mercaptoethene **15c** (61%). The formation of products **13–16** is suggested to be the result of opening of the intermediate thiirane ring under the reaction conditions.

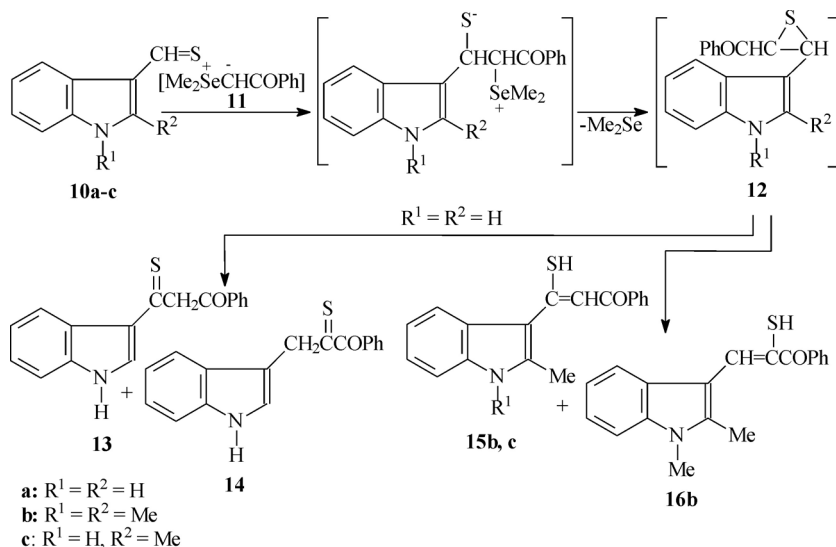

SCHEME 7

Reaction of 3-thioformyl-1,2-dimethyl- and -2-methylindole with aziridine, 2-aminoethanethiol and 2-aminoethanol. In the reaction of 3-thioformyl-1,2-dimethylindole with aziridine or 2-aminoethanethiol (MeCN, 20–50 °C, argon), instead of the expected 2-(1,2-dimethylindol-3-yl)-1,3-thiazolidine (**17**) its acyclic isomer, 3-(2-mercaptoethyliminomethyl)-1,2-dimethylindole (**18a**), was obtained in a yield of 50 and 62%, respectively (scheme 8) [22].

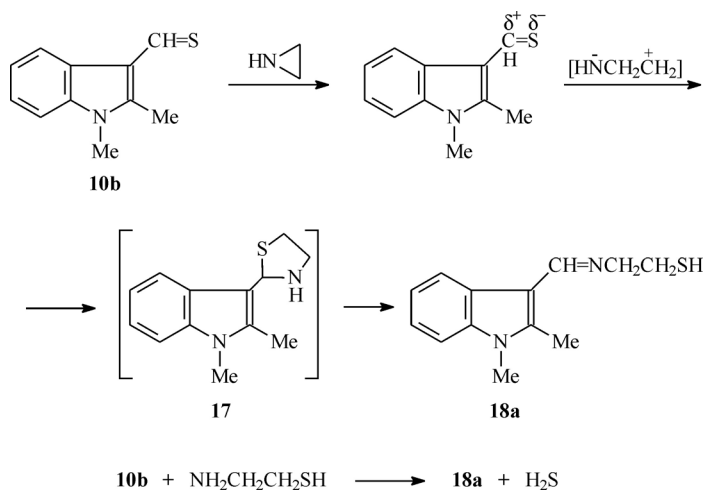

SCHEME 8

Indole **10c** reacted with 2-aminoethanethiol to give 3-(2-mercaptoethyliminomethyl)-2-methylindole (**18b**) (32%), which on reaction with excess 2-aminoethanethiol afforded 3-[2-(2-aminoethyldithio)ethylaminomethyl]-2-methylindole (**19**) in 40% yield (scheme 9) [22].

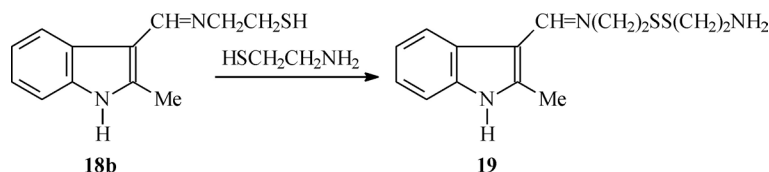

SCHEME 9

Upon reaction with thioaldehyde **10c**, 2-aminoethanol behaves as an ambident nucleophile, which leads to 3-(2-hydroxyethyliminomethyl)-2-methylindole (**20**) (48%), 3-[(2-aminoethoxy)mercaptomethyl]-2-methylindole (**21**) and azomethine thiol **18b** (scheme 10) [22].

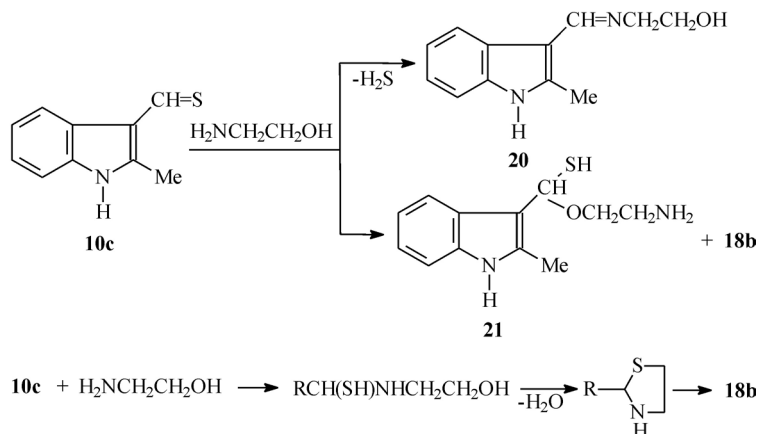

SCHEME 10

Complexation. 3-Thioformylindole (**10a**) and its derivatives **10b–d** represent original ligands since they harbor both a thiocarbonyl group and a nitrogen-containing heterocyclic system. The complexing ability of the above thioaldehydes with respect to Co, Ni, Cu, Zn, Cd, Hg, and Pb ions has been studied [11].

Depending on the structure of thioaldehyde, the nature of the metal and the salt anion, diverse complex compounds have been prepared. 3-Thioformyl-1,2-dimethylindole (**10b**) is characterized by the formation of 2:1 and 1:1 molecular complexes with transition and heavy metal salts. The reactions of thioformylindoles **10a, c, d** containing an N–H bond proceed in several ways to offer metal-containing compounds of various composition. The complexes so-obtained possess paramagnetic properties.

3. *N*-(Cyclohex-2-en-1-ylidene)immonium 3-hetero-substituted salts in the reactions of nucleophilic substitution

3.1 Hydrothiolysis

A systematic study of the reactions of *N*-(3-alkoxycyclohex-2-en-1-ylidene)immonium salts (**22**, Y = OAlk), their 3-alkylthio- (**22**, Y = SAlk) and 3-chloro-substituted analogs (**22**, Y = Cl) with hydrogen sulfide or sodium hydrosulfide at low temperature has afforded their conversion into enaminothioketones **24** in two stages (scheme 11) [3–7].

In stage 1, hydrothiolysis of the C1=N⁺ bond proceeds smoothly in the temperature range from –60 to –40°C and in high yields (78–98%), leading to previously unknown 3-substituted cyclohex-2-ene-1-thiones **23** that contain rare groups of atoms: RO–C=C–C=S,

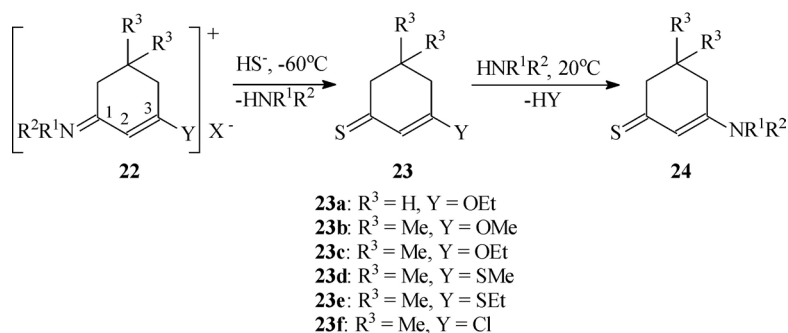

R¹ = H, Alk, cyclo-Alk; R² = H, Alk, Ar, cyclo-Alk; R³ = H, Me;
 Y = OAlk, SAlk, Cl; X = BF₄, ClO₄, I

SCHEME 11

RS-C=C-C=S, Cl-C=C-C=S [6]. This reaction opens up a general approach to the synthesis of β-heterosubstituted α, β-unsaturated thioketones. Stage 2, involving the aminolysis of stable intermediates **23**, proceeds across the C₃-Y bond at 20 °C to afford enaminothioketones **24** in high yield (70–80%) (scheme 11) [6, 7].

The salts **22** react with hydrogen sulfide only in a bipolar aprotic solvent (DMF, DMSO, HMPTA) capable of selectively solvating cations, thus weakening the H⁺ ···⁻SH bond and, consequently, increasing the nucleophilicity of sulfhydryl anion.

As the reaction requires certain temperature conditions, DMF is the most adequate solvent for the transformation of **22** into **23**. Addition of a highly basic amine significantly accelerates the process and increases the yield of target product **23**.

At 20 °C *i.e.* without isolation of intermediate the transformation **22** → **24** is completed to afford enaminothioketone **24** in a relatively moderate yield (~10%). In this case the amine formed in stage 1 is bound to a considerable extent by a split-off acid (HBF₄, HClO₄, HI) and hydrogen sulfide, thus impeding further fast conversion of **23** into **24**.

The two-stage **22** → **23** → **24** process was monitored using thin-layer chromatography and spectrophotometry. With Y = OMe, R¹R² = (CH₂)₂O(CH₂)₂, R³ = Me, X = I, for example, this transformation is accompanied sequentially by a bathochromic and further hypsochromic shift of the long wave-length band in the electron spectra as the solution changes from colorless to crimson and finally to yellow: λ_{max}286 nm(lgε3.8) → λ_{max}390 nm(lgε4.6) → λ_{max}328 nm(lgε4.4) [6].

Only with *N,N*-disubstituted immonium salts **22** low-temperature hydrothiolysis leads to exclusively compounds **23**. *N*-Mono-substituted salts **22** (Y = OAlk) react with hydrogen sulfide in DMF in the presence of Et₃N to form a mixture of products that contains small amounts of alkoxythioketones **23** (Y = OAlk) and the corresponding enaminothioketone **24**. This may be because, in a basic medium, *N*-mono-substituted salts undergo deprotonation and readily go to less reactive bases with an AlkO-C=C-C=N- group [6].

3.2 Methanethiolysis of *N*-(5,5-dimethyl-3-methylthiocyclohex-2-en-1-ylidene)morpholinium iodide

Unexpectedly, *N*-(5,5-dimethyl-3-methylthiocyclohex-2-en-1-ylidene)morpholinium iodide (**22a**), when treated with excess methanethiol in DMF in the presence of Et₃N, formed 5,5-dimethyl-3-methylthiocyclohex-2-ene-1-thione (**23d**) (yield 60%) (scheme 12) [23]. As reported [1], 3-alkoxy- and 3-chloro-substituted analogs of these salts react with alkanethiols across the C3 atom.

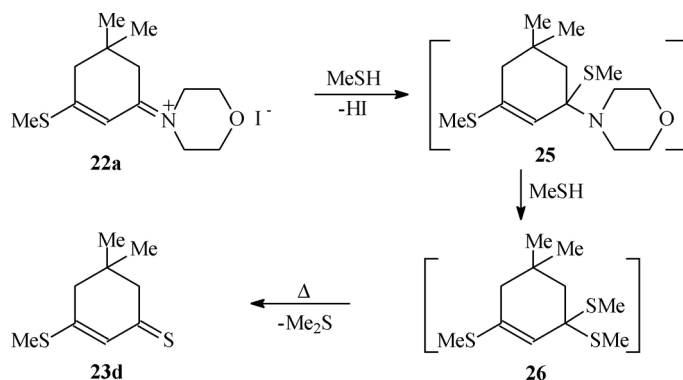

Evidently, reaction stage 1, *i.e.* attack at the $C1=N^+$ bond, results in the formation of *gem*-aminomercaptal **25**, which further reacts with methanethiol to give 5,5-dimethyl-1,3,3-tris(methylthio)cyclohex-1-ene (**26**). Disproportionation of the latter leads to methylthioketone **23d** and dimethyl sulfide. This reaction provides a further example of the action of a “soft” nucleophile on the $C_1=N^+$ bond in immonium salts of type **22**.

3.3 Hydrolysis, alcoholysis, aminolysis and cyanolysis

The reaction of *N*-(3-alkoxy-5,5-dimethylcyclohex-2-en-1-ylidene)immonium iodides and tetrafluoroborates (**22**, $Y = OAlk$, $X = BF_4, I$) with water in the presence of Et_3N at $20^\circ C$ affords 3-alkoxy-5,5-dimethylcyclohex-2-ene-1-ones **27**, the products of hydrolysis across the $C_1=N^+$ bond (scheme 13) [24]. In the presence of hydrochloric acid, alkoxy-substituted salts **22** are hydrolyzed to the corresponding enamino ketones [2].

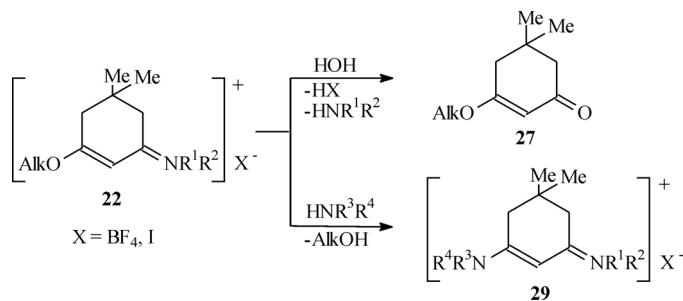

In the reaction of *N*-(5,5-dimethyl-3-methoxycyclohex-2-en-1-ylidene)morpholinium perchlorate (**22b**) with sodium methanolate in methanol at $20^\circ C$ nucleophilic attack on the C3 atom affords 3,3-dimethoxy-5,5-dimethyl-1-morpholinocyclohex-1-ene (**28**) (yield 78%). This reaction demonstrates the first synthesis of an enamino ketone acetal (scheme 14) [25].

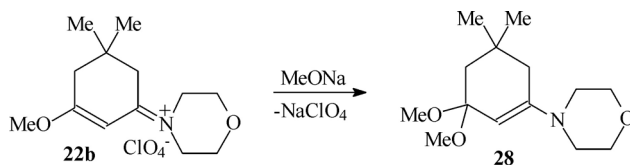

With ammonia, primary and secondary amines, compounds **22** ($Y = \text{OAlk}$) form the salts of corresponding enaminoimines **29** – the products of aminolysis across the $\text{C}_3\text{--OAlk}$ bond [2] (see scheme 13).

N-(5,5-Dimethyl-3-chlorocyclohex-2-en-1-ylidene)piperidinium perchlorate (**22c**) reacts with potassium cyanide to furnish 3-chloro-5,5-dimethyl-1-piperidino-1-cyanocyclohex-2-ene (**30**) (scheme 15) [6].

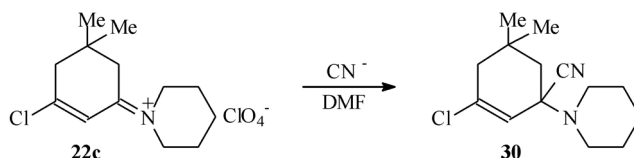

SCHEME 15

The formation of geminal aminonitrile **30** confirms that, in stage 1 of the overall reaction of nucleophilic substitution in salts of type **22**, the “soft” nucleophile is added to the $\text{C1}=\text{N}^+$ bond, but not to the $\text{C2}=\text{C3}$ bond.

3.4 Quantum-chemical calculations

Calculations of charge density in cations **31** and **32** have been carried out by the CNDO method in original parametrization [6]. The results were presented for only the chemically active $\text{Y--C=C--C=N}^+\text{Me}_2$ fragment, and were demonstrated on the molecular diagrams of cations **31** and **32** (see table 2) (the positive charge initial localization in cations **31**, **32** is ~ 2 eV more energetically advantageous on the *N* atom than on *O* or *S* atoms).

Table 2. Results of the calculation of *N*-(3-methylthio)-**31**- and -(3-methoxycyclohex-2-en-1-ylidene)-*N*, *N*-dimethylimmonium **32**.

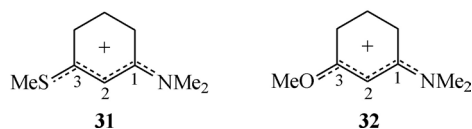

Atom or bond	Form 31			Form 32		
	q_i, e	k_i	w	q_i, e	k_i	w
N	-0.063	-	-	-0.071	-	-
C(1)	0.275	0.36	-	0.280	0.42	-
C(2)	-0.104	-	-	-0.191	-	-
C(3)	0.211	0.26	-	0.312	0.25	-
S	0.021	-	-	-	-	-
O	-	-	-	-0.182	-	-
C(1)=N ⁺	-	-	1.560	-	-	1.518
C(1)-C(2)	-	-	1.120	-	-	1.152
C(2)=C(3)	-	-	1.642	-	-	1.588
C(3)-S	-	-	1.071	-	-	-
C(3)-O	-	-	-	-	-	1.147

Designations: q_i –charges on atoms; k_i –relative contribution from atomic π -orbitals to the lower free molecular orbital; w –indexes according to Wieberg.

As shown by analysis of molecular diagrams, in the case of 3-methylthio-substituted cation **31**, nucleophile attack, both “soft” and “hard”, across the $C=N^+$ bond is preferred and the direction of the reaction is governed by orbital and charge control.

With 3-methoxy-substituted cation **32**, “soft” nucleophiles should mainly react across the $C=N^+$ bond (orbital control prevails), whereas the attack of “hard” ones is directed to the $C-O$ bond (charge control dominates), which may be explained in terms of the higher electronegativity of the MeO group compared with MeS. Thus, quantum-chemical calculation confirms experimental data concerning the preferred attack of “soft” nucleophiles across the $C=N^+$ bond of β -hetero-substituted α , β -unsaturated immonium salts.

4. Interaction of *N,N*-disubstituted 3-alkylthio- and 3-alkoxy-2-phenyl-1-indenyliide neimmonium salts with nucleophilic reagents

The reaction of salts **33a–c**, **e** with test “hard” ($AlkO^-$, AcO^-), “intermediate” (CN^-) and “soft” ($AlkS^-$) anion-nucleophiles in methanol and a methanol–hexane system has been studied (scheme 16) [26, 27]. The reaction of the salt **33b** with alkoxides or sodium acetate proceeds rapidly and regioselectively across the $C_1=N^+$ bond to form 1-alkoxy- and 1-acetoxy-1-*N,N*-dimethylamino-3-methylthio-2-phenylindenes **34a,b** and **34c**, respectively. The action of sodium cyanide on the salts **33a–c** is also directed at the $C_1=N^+$ bond to lead to 1-cyano-1-*N,N*-dimethylamino-2-phenyl-3-ethoxyindene (**34d**) and 1-*N,N*-dimethylamino-3-methylthio-2-phenyl-1-cyanoindene (**34e**). Thus, it can be inferred that, with respect to indenylideneimmonium salts **33**, the cyanide anion behaves as a “hard” nucleophile.

The attack of methanethiolate is directed to only the second electrophilic center in the immonium salts **33a**, **b**, *i.e.*, at the C_3 atom. Thus, the salt **33a** affords 3-*N,N*-dimethylamino-1-methylthio-2-phenyl-1-ethoxyindene (**35a**), whereas the salt **33b** forms 3-*N,N*-dimethylamino-1,1-bismethylthio-2-phenylindene (**35b**).

Hydroxide and hydrosulfide anions react in the same direction as their methyl-substituted analogs but lead to the products of nucleophilic substitution, *i.e.*, 3-methylthio-2-phenyl-1-indenone (**36**) and 3-amino-2-phenylindene-1-thiones (**37**), respectively (scheme 16) [28].

The data obtained indicate that the structure of adducts **34** and **35** is governed by kinetic control of **33** \rightarrow **34** and **33** \rightarrow **35** transformations. In accordance with the HSAB principle, the C_1 atom in indenylideneimmonium cations may be considered in this case as “hard”, whereas the C_3 atom is a “soft” sp^2 -reactive center. However, the observed relationship and the above suggestion are inversely changed after a careful study of the interaction of the immonium salts **33a**, **b**, **d–f** with covalent nucleophiles [27].

Thus, ammonia and methylamine attack the C_3-Y bond in 3-ethoxy- and 3-alkylthio-derivatives **33d** and **33e**, **f** to form *N,N*-unsymmetrical 3-amino-1-imino-2-phenylindenes **38a**, **b**. Conversely, the attack of “soft” hydrogen sulfide (like that of “hard” anions AcO^- , RO^- , HO^-) takes place only at the $C_1=N^+$ bond in 3-ethoxy- and 3-alkylthio-derivatives **33a**, **d** and **33b**, **f**, leading to 3-ethoxy- and 3-alkylthio-substituted **39a** and **39b**, **c** 2-phenyl-1-indenethiones, respectively (scheme 16).

As in the reaction with anionic nucleophiles, the result of these transformations does not depend significantly on the structure of salts **33** or on the exact temperature within the range from -30 to $20^\circ C$.

5. 3-Alkoxy-, -alkylthio- and -chlorocyclohex-2-ene-1-thiones

5.1 Physical and spectral properties

Cyclohex-2-ene-1-thiones **23** [3–7] are readily melting crystalline or oily substances that are crimson or violet, and are readily soluble in organic solvents but insoluble in water.

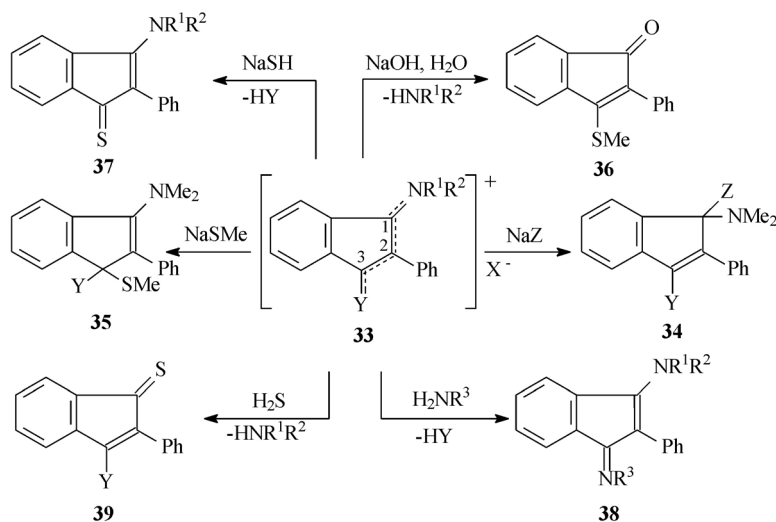

33: R¹ = R² = Me, Y = EtO, X = BF₄ (**a**); R¹ = R² = Me, Y = MeS, X = I (**b**); R¹ = R² = Me, Y = MeS, X = ClO₄ (**c**); R¹, R² = (CH₂)₅, Y = EtO, X = BF₄ (**d**); R¹, R² = (CH₂)₅, Y = MeS, X = I (**e**); R¹, R² = (CH₂)₅, Y = EtS, X = BF₄ (**f**). **34**: Y = MeS, Z = MeO (**a**); Y = MeS, Z = *t*-BuO (**b**); Y = MeS, Z = AcO (**c**); Y = EtO, Z = CN (**d**); Y = MeS, Z = CN (**e**). **35**: Y = EtO (**a**); MeS (**b**). **37**: R¹ = R² = Me (**a**); R¹, R² = (CH₂)₅ (**b**). **38**: R¹, R² = (CH₂)₅, R³ = H (**a**); R¹, R² = (CH₂)₅, R³ = Me (**b**). **39**: Y = EtO (**a**); MeS (**b**); EtS (**c**).

SCHEME 16

The IR spectra of thioketones **23** exhibit characteristic absorption bands of the double bond in the cyclohexene ring and thiocarbonyl group in the 1530–1590 and 1075–1125 cm⁻¹ regions, respectively [3–7].

In the ¹H NMR spectra of these compounds the signals of main groups of protons are fixed separately. For example, the ¹H NMR spectrum (CDCl₃, δ, ppm) of 5,5-dimethyl-3-ethoxycyclohex-2-ene-1-thione (**23c**) presents the following peaks: 1.03 s [5-C(CH₃)₂], 1.36 t (OCCH₃), 2.22 d (4-CH₂), 2.72 s (6-CH₂), 3.93 q (OCH₂), 6.42 t (2-CH=); ²J(OCH₂CH₃) = 7.0 Hz [7].

The electronic spectra of cyclohex-2-ene-1-thiones **23b** and **23d** exhibit bands of *n* → π* (λ_{max} 498–564 nm, lgε_{max} 1.40–1.82) and π → π* (λ_{max} 315–359 nm, lgε_{max} 4.49–4.53) transitions [29].

5.2 Chemical properties

3-Hetero-substituted cyclohexenethiones **23** are extremely reactive and rather accessible [3–7]. They serve as convenient synthons in organic synthesis. Their reactions with nucleophilic partners across the C–Y bond proceed with great ease.

Reaction with S-nucleophiles. Synthesis and properties of dithiodimedone. Conjugated thioketones **23** permit the synthesis of dithiodimedone, a representative of a rare type of compounds, β-dithiodiketones [30]. 5,5-Dimethyl-3-mercaptocyclohex-2-ene-1-thione (**40**) has been prepared in quantitative yield by the thiolysis of **23b–f** with sodium hydrosulfide or sodium sulfide in an inert atmosphere at 0–20 °C in methanol (scheme 17). Compound **40** has also been obtained in the reaction of dimedone **41** with hydrogen sulfide in alcohol in the presence of hydrogen chloride at –50 °C (35% yield) (scheme 17) [30].

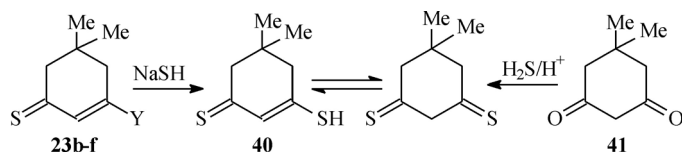

SCHEME 17

The existence of dithiodimedone tautomer **40** in the enethiolthionic form was established by ^1H NMR and IR spectroscopy. ^1H NMR spectrum (CDCl_3 , δ , ppm) at -70°C : 1.00 s [$5-\text{C}(\text{CH}_3)_2$], 2.27 d ($4-\text{CH}_2$), 2.66 s ($6-\text{CH}_2$), 3.97 s ($=\text{C}-\text{SH}$), 6.80 t ($2-\text{CH}=\text{C}$). Temperature elevation or solvent dissolution cause an upfield displacement of the S-H signal as well as coalescence of the $4-\text{CH}_2$ and $6-\text{CH}_2$ group signals due to a fast (on the NMR time scale) intermolecular proton exchange of type $-\text{C}=\text{S} + \text{HS}-\text{C} \rightleftharpoons -\text{C}-\text{SH} + \text{S}=\text{C}-$.

The activation energy of this process ($\Delta G_c^\ddagger = 13.1 \text{ kcal mol}^{-1}$) was determined using dynamic ^1H NMR. This shows that the proton exchange in enethiolthione **40** is much slower than in its oxygen analog **41** ($\Delta G_c^\ddagger < 8 \text{ kcal mol}^{-1}$). ^1H NMR spectrum at 20°C : 2.49 s ($4-\text{CH}_2$ and $6-\text{CH}_2$), 3.32 s ($=\text{C}-\text{SH}$). Cooling the solution leads to the initial spectrum. The IR spectrum of enethiolthione **40** (ν , cm^{-1}): 2500 (SH), 1120 ($\text{C}=\text{S}$), 1550 ($\text{C}=\text{C}$ in the cyclohexene ring) [30].

Notably, dithiodimedone contains three methylene groups potentially capable of taking part in the formation of bis(enethiolic) form **40-A**. Thus, the action of Et_3N on the solution of mercaptothioketone **40** in chloroform in the presence of lead dioxide results in the formation of the macrocyclic compound 5,5,12,12,19,19,26,26-octamethyl-1,2,8,9,15,16,22,23-octathia-3,7,10,14,17,21,24,28-tetramethino-3,4,10,11,17,18,24,25-cyclooctacosatetraene (**42**) in 78% yield (scheme 18) [31].

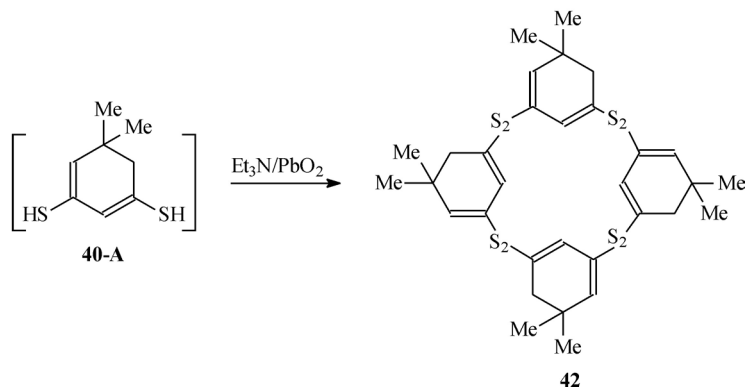

SCHEME 18

Reaction with 1,2-ethanedithiol. In the reaction of 5,5-dimethyl-3-methoxycyclohex-2-ene-1-thione (**23b**) with an *S,S*-binucleophile, 1,2-ethanedithiol, two reaction centers of **23b** are functionalized and, as a result, dispiro[bis(1,3-dithiolane)]-1,2';3,2'-(5,5-dimethylcyclohexane) (**43**) is formed (yield 70%) (scheme 19) [32]. Stage 1 of the reaction involves substitution of the MeO group followed by the addition of reagent to the $\text{C}=\text{S}$ bond. The opposite sequence is less likely, since methoxy group reactivity would be significantly weakened due to disruption of the conjugation system by initial conversion of the thione.

Aminolysis. Aminolysis of 3-substituted thioketones **23** provides a universal process for the preparation of 3-aminocyclohex-2-ene-1-thiones **24** [6, 7]. In this way it was

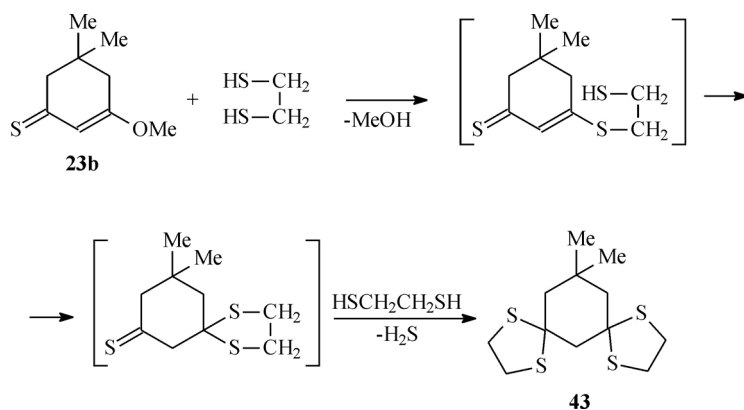

SCHEME 19

possible to synthesize enaminothioketones **24** with different substituents at the nitrogen atom. Amines employed in the reaction included ammonia, primary aliphatic (methylamine, benzylamine, *N,N*-dimethylaminoethylamine) and aromatic (aniline and its derivatives) amines, secondary amines (dimethylamine, dibutylamine, pyrrolidine, piperidine, morpholine, perhydro-1,4-thiazine-1-oxide, *etc.*).

The aminolysis was performed at 20 °C in methanol although other solvents such as benzene, chloroform, DMF can also be used. The mild conditions allow the use of 2-hydroxyethylamine, 1,4-phenylenediamine and sulfanylic acid while retaining the second nucleophilic center. For reactions with amines it is most convenient to employ 5,5-dimethyl-3-methoxycyclohex-2-ene-1-thione (**23b**), since this compound is rather stable and forms enaminothioketones **24** in nearly quantitative yield.

Kinetic studies of the aminolysis of 3-alkoxy- and 3-alkylthio-5,5-dimethylcyclohex-2-ene-1-thiones **23** using spectrophotometry indicate that the reaction follows an 1,4-addition-elimination. For methylthio-substituted thioketone **23d** the formation of a stable intermediate was proven [29].

6. 3-Aminocyclohex-2-ene-1-thiones

For the synthesis of 3-aminocyclohex-2-ene-1-thiones **24**, along with the aminolysis of 3-alkoxy-substituted thioketones **23**, other methods have been developed. These are sulfuration of the corresponding 3-aminocyclohex-2-ene-1-ones with phosphorus decasulfide, and hydrothiolysis of 1-amino-3-iminocyclohex-1-enes [7]. The reaction with phosphorus decasulfide failed to give high yields of compounds **24**. The interaction of enaminoimines with hydrogen sulfide leads to only *N*-mono-substituted enaminothioketones **24**.

6.1 Physical and spectral properties

3-Aminocyclohex-2-ene-1-thiones **24** are yellow-orange crystalline substances that are soluble in most organic solvents [6, 7]. The IR spectra of enaminothioketones **24** show characteristic absorption bands in the regions 1040–1085 cm⁻¹ (ν C=S); 1515–1555 (C=C in cyclohexene ring); 1475–1494 and 1575–1594 (C=C in aromatic rings); 3160–3250 (NH). The electron absorption spectra of thiones **24** are characterized by intense bands in the λ_{\max} 365–386 nm range, less intense absorptions in the range 246–290 nm range and “red” absorptions in the 217–260 nm range [29].

The ¹H NMR spectra of thiones **24**, run in various solvents and at different temperatures provide strong evidence for an enaminothioketonic structure of the samples. At certain concentrations of the sample and, as a rule, upon its heating the vinyl proton signal is observed

as a triplet, whereas the signal of the 4-CH₂ proton group is expressed as a doublet (allylic coupling) with *J* values equal to 1 Hz [7].

Using dynamic ¹H NMR, it is possible to determine the barrier of hindered rotation about the partial C–N bond in enaminothioketones **24** due to a contribution of the bipolar mesomeric form (S=C–C=C–NR¹R² ↔ [–]S–C=C=C=N⁺R¹R²) to their structure. Thus, in the ¹H NMR spectrum of 5,5-dimethyl-3-*N,N*-dimethylaminocyclohex-2-ene-1-thione (**24a**) with decreasing temperature the signal of anisochronic *N*-methyl groups undergoes changes that are “typical” of decelerating the rotation ($\Delta G_c^\ddagger = 14.4 \text{ kcal mol}^{-1}$) [33].

6.2 Chemical properties

Protonation and hydrolysis. As a rule, in enaminothioketones, amides, and thioamides “hard” acids (HCl, HClO₄) in water protonate a “hard” nucleophilic center (*N*, *O*), whereas carboxylic acids in DMSO, chloroform, acetone, etc. act as “soft” acids and protonate “soft” centers (*C*, *S*) [34, 35]. The protonation of thione **24a** by “soft” (CCl₃COOH) and “hard” (70% HClO₄) acids in acetone has been studied using ¹H NMR spectroscopy (scheme 20) [33].

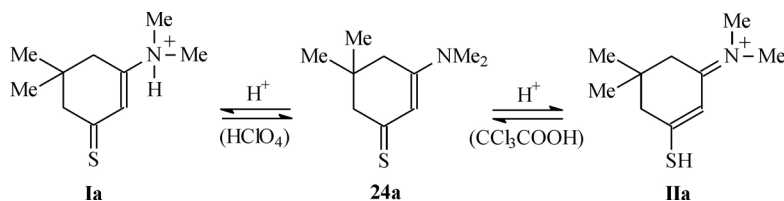

SCHEME 20

In each case, the hydrolysis of enaminothioketones **24** would probably be predetermined by the formation of protonated substrates of type **I** or **II**. Indeed, the hydrolysis of thiones **24** is independent of the character of substitution at the nitrogen atom in the presence of HCl (or perchloric acid) and leads only to the diketone **41** (scheme 21) [33]. This indicates that

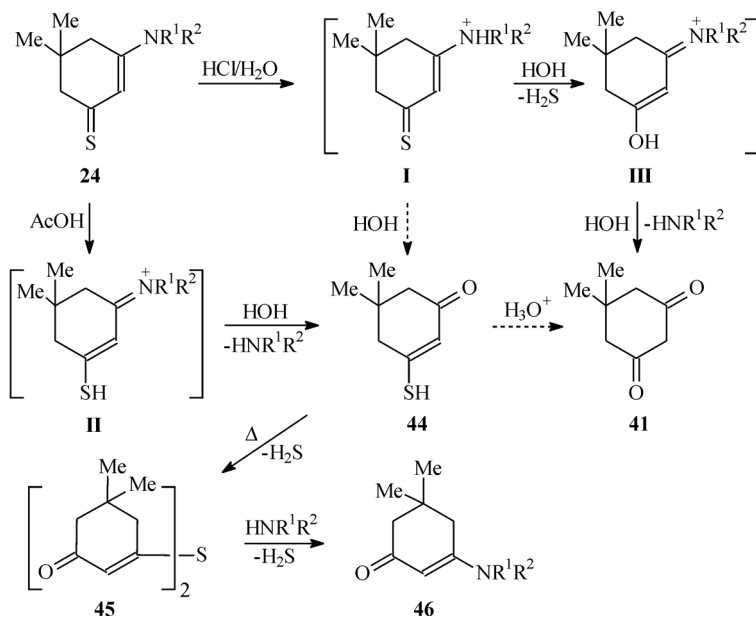

SCHEME 21

enammonium cation **I**, resulting from proton addition to the N atom, is hydrolyzed at the thiocarbonyl group. Further, according to usual scheme, the hydrolysis of the intermediate immonium cation **III** occurs to give the diketone **41**.

Hydrolysis of enaminothioketones **24** in 96% acetic acid follows another scheme to furnish the end products bis(5,5-dimethyl-3-oxocyclohex-1-enyl) sulfide (**45**) and enaminothioketones **46** (scheme 21) [33]. Protonation of the initial thioketones **24** across the sulfur atom must lead to immonium cation **II** and, due its hydrolysis, to mercaptoketone **44**.

3-Aminocyclohex-2-ene-1-thiones **24** are stable to alkaline hydrolysis up to 100 °C. At higher temperatures a mixture of enethiol **44** and diketone **41** is formed [33].

6.3 Bacteriostatic action

3-Aminocyclohex-2-ene-1-thiones **24** are moderately toxic (LD_{50} 1280–3000 mg kg^{-1}) and possess a clearly expressed antistaphylococcus activity (figure 3) (minimal bacteriostatic concentration 12.5 mg ml^{-1}) not only to reference strain 209-P but also with respect to intrahospital staphylococcus strains 25 and 36. They are more effective than the known antibacterial agent streptomycin sulfate (50 mg ml^{-1} at LD_{50} 328 mg kg^{-1}) [36]. The dependence of the bacteriostatic action of cyclohexenethiones **24** on their structure was established using a special algorithmic system [36].

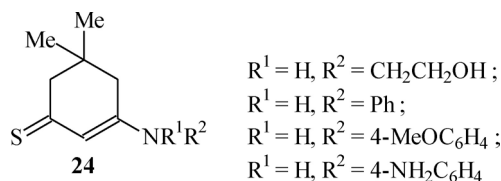
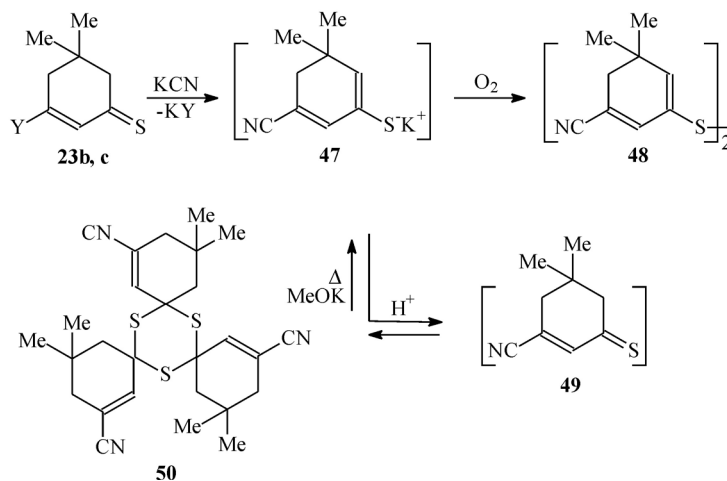

Figure 3.

7. 5,5-Dimethyl-3-cyanocyclohex-2-ene-1-thione trimer

Cyclohexenethiones **23**, **24**, **40** contain β -position substituents ($Y = NR_2, OR, SH, SR, Cl$), that possess +R properties. The possibility of mesomeric stabilization according to the scheme $Y-C=C-C=S \rightleftharpoons ^+Y=C-C=C-S^-$ is responsible for their stability in the thioketone form. The synthesis of thioketones having an analogous group in which Y corresponds to CN, NO_2 , SO_2R and other groups inducing the -R effect is difficult using traditional means.



SCHEME 22

As established previously [37], 3-alkoxy-5,5-dimethylcyclohex-2-ene-1-thiones **23b, c** readily react with potassium cyanide in methanol at 20 °C to form, in the solution, sodium 5,5-dimethyl-3-cyanocyclohexa-2,6-diene-1-thiolate (**47**) (scheme 22). The cyclohexadienic structure of **47** was proven by ¹H NMR spectroscopy using the data for analogous model structures and by oxidation to the corresponding disulfide **48**.

When the reaction mixture is treated with carbonic acid, instead of the expected 5,5-dimethyl-3-cyanocyclohex-2-ene-1-thione (**49**) its trimer, trispiro[tris(5',5'-dimethyl-3'-cyanocyclohex-2'-ene)-1',2';1',4';1',6-(1,3,5-trithiane)] (**50**) was obtained. This compound can also be formed from chlorocyclohexenethione **23f** and potassium cyanide. IR spectrum of trithiane **50** (ν , cm⁻¹): 1565, 1630 (C=C); 2230, 2240 (C≡N); 2880–2970 (C–H); ¹H NMR spectrum (CDCl₃, δ , ppm): 1.03 narrow m [5–C(CH₃)₂], 1.78–2.50 broad m (4- and 6–CH₂).

8. 1,7-Dithio-substituted systems S=C–C=C–S–C=C–C=S

The chemistry of dithiocarbonyl compounds is not well explored. Known representatives of compounds of this class are often unstable and the available data of their synthetic routes and properties are scarce [8, 30, 38]. 1,7-Dithiocarbonyl compounds are practically unknown.

A systematic study of synthetic routes to 1,7-dithio-substituted systems containing the structural fragment S=C–C=C–S–C=C–C=S has been carried out [11, 39]. With this goal the hydrothiolysis of immoniothio-, immoniooxo- and bisimmonio-substituted α , β -unsaturated sulfides of the propenic, cyclohexenic and indenic series have been investigated.

8.1 Synthesis of immonium salts – precursors of 1,7-dithiocarbonyl compounds

Methods for the synthesis of previously unknown carbofunctional symmetrical and unsymmetrical α , β -unsaturated sulfides, potential precursors of 1,7-dithiocarbonyl compounds and their mono oxygen analogs, have been elaborated [40–42].

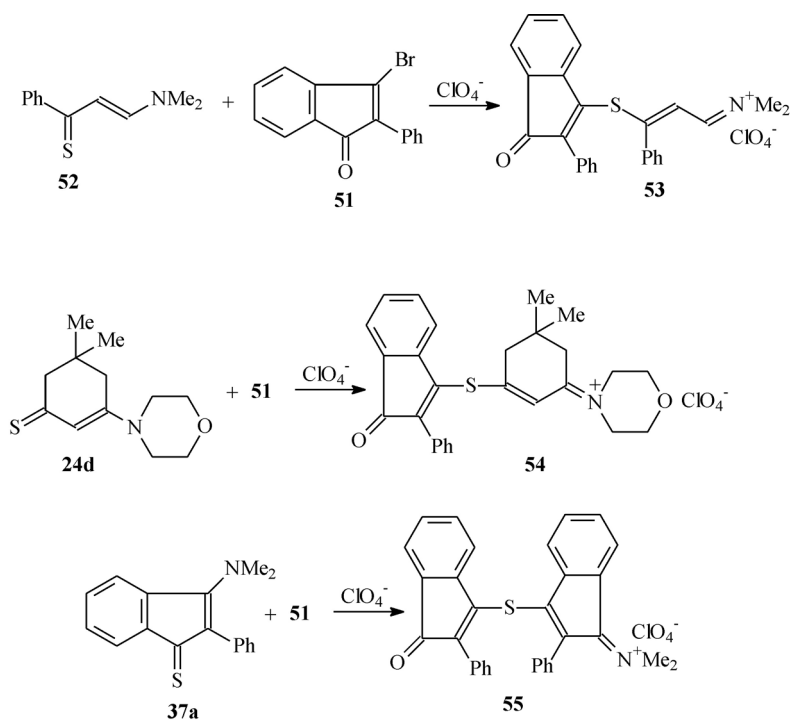

SCHEME 23

Reaction of 3-bromo-2-phenylinden-1-one with enaminothioketones as a synthetic route to immoniooxo-substituted sulfides. 3-Bromo-2-phenylinden-1-one (**51**) in the presence of perchlorate anion reacts with the thiocarbonyl group of 3-*N,N*-dimethylamino-1-phenylprop-2-ene-1-thione (**52**), 5,5-dimethyl-3-morpholinocyclohex-2-ene-1-thione (**24d**), 3-*N,N*-dimethylamino-2-phenylindene-1-thione (**37a**) under mild conditions (methanol, 40 °C) to form 1-*N,N*-dimethylimmonio-3-phenylprop-2-en-3-yl 1-oxo-2-phenylinden-3-yl sulfide perchlorate (**53**) (72%), 5,5-dimethyl-3-morpholinocyclohex-2-en-3-yl 1-oxo-2-phenylinden-3-yl sulfide perchlorate (**54**) (98%), and 1-*N,N*-dimethylimmonio-2-phenylinden-3-yl 1-oxo-2-phenylinden-3-yl sulfide perchlorate (**55**) (79%), respectively (scheme 23) [40].

Condensation of 3-mercapto-substituted thioketones with immonium halo derivatives perchlorates – a route to the synthesis of immoniothiooxo-substituted salts. 5,5-Dimethyl-3-mercaptocyclohex-2-ene-1-thione (**40**) reacts with *N*-(5,5-dimethyl-3-chlorocyclohex-2-en-1-ylidene)morpholinium perchlorate (**22d**) in acetonitrile at 10 °C to give 5,5-dimethyl-1-morpholinocyclohex-2-en-3-yl 5,5-dimethyl-1-thioxocyclohex-2-en-3-yl sulfide perchlorate (**56**) in 39% yield (scheme 24) [41].

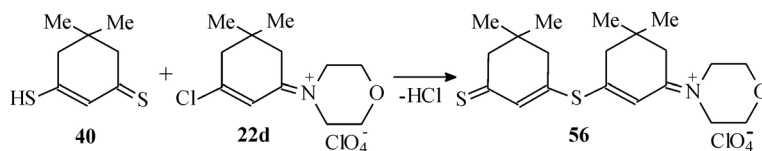

SCHEME 24

This illustrates an approach to the preparation of immoniothiooxo-substituted α, β -unsaturated sulfides. Compounds of this type are of interest not only due to the presence of a thiocarbonyl group, but they can also be used as starting materials in the synthesis of conjugated dithiones and their oxygen analogs.

Preparation of bisimmonio-substituted α, β -unsaturated sulfides by the reaction of enaminothioketones with immonium halo derivatives perchlorates. *N*-(3-Chloro-3-phenylprop-2-en-1-ylidene)-*N,N*-dimethylimmonium perchlorate (**1**) or *N*-(3-chloro-5,5-dimethylcyclohex-2-en-1-ylidene)morpholinium perchlorate (**22d**) react with enaminothioketones **24d**, **37a**, **52** (methanol, 30–40 °C) to form the corresponding symmetrical and unsymmetrical 1,1'-bisimmonio-substituted α, β -unsaturated sulfides: bis(1-*N,N*-dimethylimmonio-3-phenylprop-2-en-3-yl) sulfide diperchlorate (**57**) (80%), bis(5,5-dimethyl-1-morpholinocyclohex-2-en-3-yl) sulfide diperchlorate (**58**) (81%), 1-*N,N*-dimethylimmonio-3-phenylprop-2-en-3-yl 5,5-dimethyl-1-morpholinocyclohex-2-en-3-yl sulfide diperchlorate (**59**) (99%), 1-*N,N*-dimethylimmonio-3-phenylprop-2-en-3-yl 1-*N,N*-dimethylimmonio-2-phenylinden-3-yl sulfide diperchlorate (**60**) (84%), 5,5-dimethyl-1-morpholinocyclohex-2-en-3-yl 1-*N,N*-dimethylimmonio-2-phenylinden-3-yl sulfide diperchlorate (**61**) (67%) (scheme 25) [42].

8.2 Synthesis of thiochromene derivatives

1-*N,N*-Dimethylimmonio-3-phenylprop-2-en-3-yl 5,5-dimethyl-1-morpholinocyclohex-2-en-3-yl sulfide diperchlorate (**59**) can be transformed into thiochromene perchlorate **62** (yield 91%) (scheme 26) [43]. Heterocyclization readily occurs in methanol in the presence of catalytic Et₃N at 20 °C. Hydrolysis of **62** led to its 7-oxo derivative **63**, the structure of which was proven by X-ray diffraction.

Thus, using enaminothioketones and halo-substituted immonium salts an approach to the synthesis of sparsely available thiochromene derivatives has been found [43].

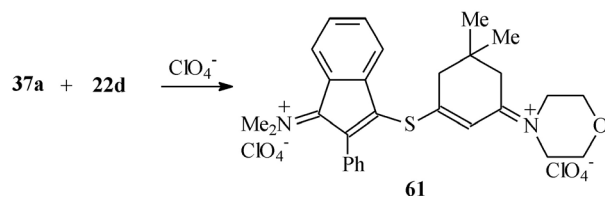
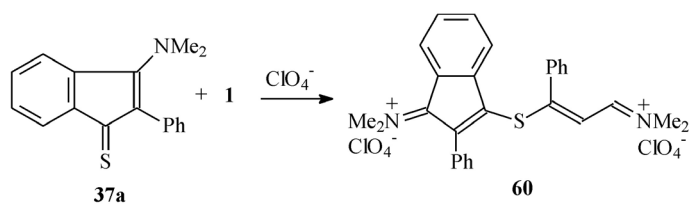
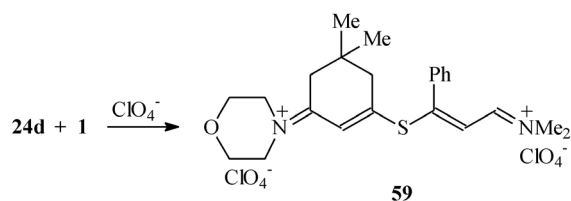
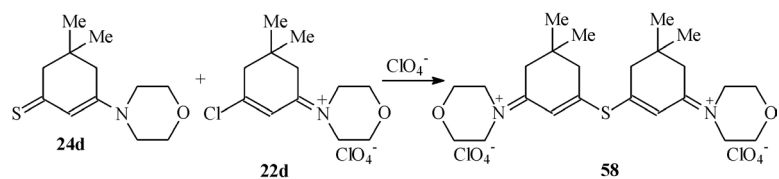
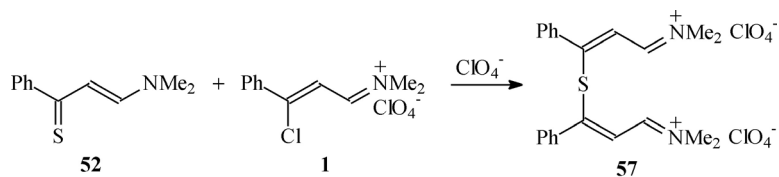

SCHEME 25

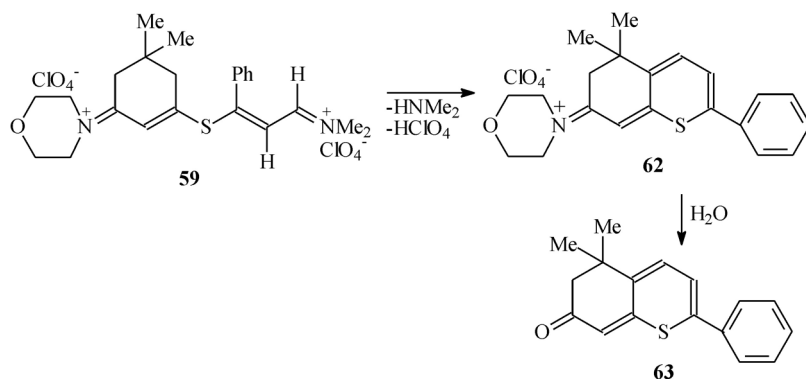

SCHEME 26

8.3 Hydrothiolysis of carbofunctional α,β -unsaturated sulfides

Interaction of immoniooxo- and immoniothioxo-substituted α,β -unsaturated sulfides with hydrogen sulfide. The reaction of perchlorate **54** with hydrogen sulfide (MeCN, Et₃N, -40°C) leads to cleavage of the sulfide bond of salt **54** to form **39** (scheme 27) [11].

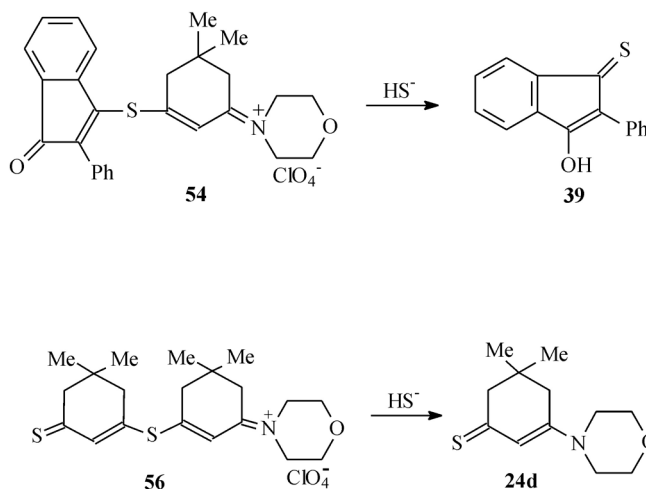

Hydrothiolysis of immoniothioxo-substituted α,β -unsaturated sulfides has been illustrated with sulfide **56** as an example (H₂S, MeCN, Et₃N, at -40 to -15°C). Formation of the target dithioxosulfide has not been observed. 5,5-Dimethyl-3-morpholinocyclohex-2-ene-1-thione (**24d**), the product of C-S bond cleavage of **56**, has been isolated from the reaction mixture (scheme 27) [41].

Hydrothiolysis of bisimmonium salts. The reaction of symmetrical diperchlorate **57** with hydrogen sulfide (MeCN, Et₃N, -40°C) leads to 3-phenyl-1-thioxoprop-2-en-3-yl 1-*N,N*-dimethylimmonio-3-phenylprop-2-en-3-yl sulfide perchlorate (**64**), the product of hydrothiolysis of one of the immonium groups of salt **57** (scheme 28) [11]. Interaction of the diperchlorate **57** with hydrogen sulfide in DMF at -50 to -60°C proceeds with both the creation of compound **64** and substitution of the two dimethylimmonium groups followed by formation of bis(3-thioxo-1-phenylpropenyl) sulfide **5** (scheme 28) [11].

Diperchlorate **59** reacts with hydrogen sulfide in DMF, involving only one immonium group, to form 3-phenyl-1-thioxoprop-2-en-3-yl 5,5-dimethyl-1-morpholinocyclohex-2-en-3-yl sulfide perchlorate (**65**) (scheme 28) [11]. Hydrothiolysis of salt **61** [H₂S, MeCN (DMF), Et₃N, at -40 to -60°C, argon atmosphere] leads to cleavage of the sulfide bond in **61** to form thioketones **24d** and **37a** (scheme 28) [11].

8.4 Bis(5,5-dimethyl-3-thioxocyclohex-1-enyl) sulfide

The first representative of 1,7-dithiones, bis(5,5-dimethyl-3-thioxocyclohex-1-enyl) sulfide (**66**), was obtained in 77% yield by the reaction of bis(5,5-dimethyl-1-morpholinocyclohex-2-en-3-yl) sulfide diperchlorate (**58**) with hydrogen sulfide in acetonitrile in the presence of a catalytic amount of Et₃N at -40°C under an argon atmosphere (scheme 29) [39]. Dithione **66** is a dark-green crystalline substance, stable in an inert atmosphere at 0°C, possessing the following data: ¹H NMR spectrum (CDCl₃, δ , ppm): 1.07 s (12H, CH₃); 2.34 d (4H, 6-CH₂, ⁴J = 1.2 Hz); 2.77 s (4H, 4-CH₂); 6.92 t (2H, HC=C, ⁴J = 1.2 Hz). IR spectrum

(KBr, ν , cm^{-1}): 1110–1120 (C=S), 1540–1548 (C=C–S). UV spectrum [CHCl_3 , λ_{max} , nm (lg ϵ): 296 (4.16), 349 (4.13), 392 (4.20), 573 (1.75). $[M]^+$ 310.

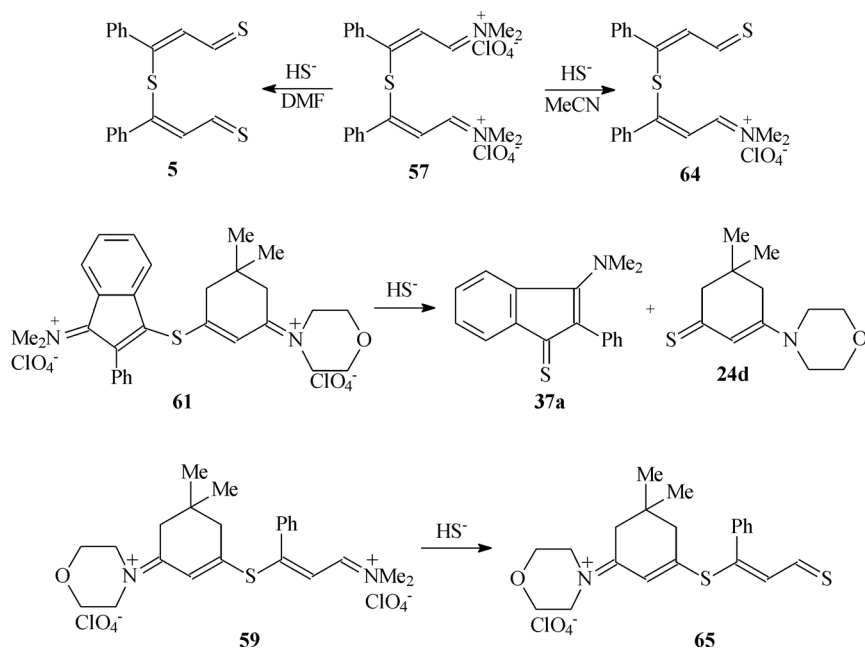

SCHEME 28

In terms of the chemistry of Scheme 29, apart from the expected dithione **66**, 5,5-dimethyl-1-morpholinocyclohex-2-en-3-yl 5,5-dimethyl-1-thioxocyclohex-2-en-3-yl sulfide perchlorate (**56**) has been isolated in 20% yield. It is the product of hydrothiolysis of one immonium group of the salt **58** [39]. The conformation adopted by dithioxosulfide **66** has been studied using two-dimensional NMR spectroscopy, dipole moments and non-empirical quantum-chemical calculations (6-31G* basis set) [44]. Results of calculations of the energies and dipole moments of four possible conformers of compounds **66** have shown the non-planar *cis-trans* conformer to be the most stable.

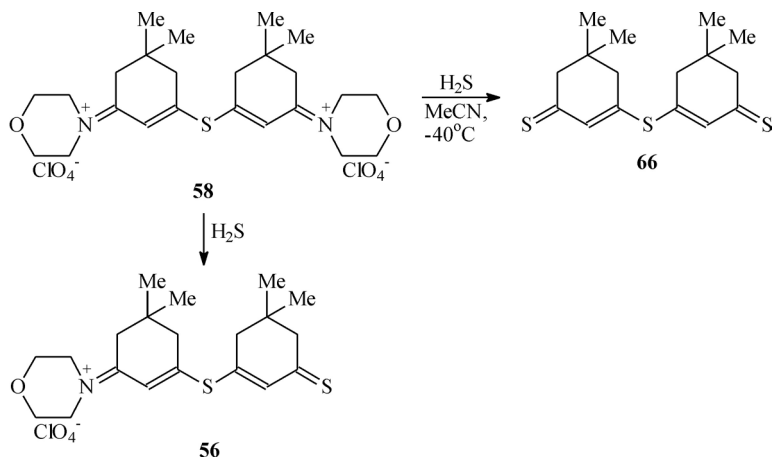

SCHEME 29

^1H and ^{13}C NMR data [δ_{C} , ppm, 232.61 (C=S)] for dithione **66** in CDCl_3 solution are also indicative of only one conformation. A comparison of the ^{13}C NMR chemical shifts of compounds **66** and model 5,5-dimethyl-3-methylthiocyclohex-2-en-1-thione (**23d**) has been carried out. All the data obtained allowed a conclusion concerning the existence of dithione-sulfide **66** in the gas phase and in solution, presumably as a non-planar *cis-trans* conformer (figure 4) [44].

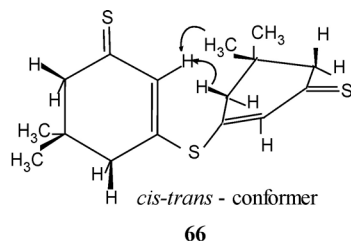
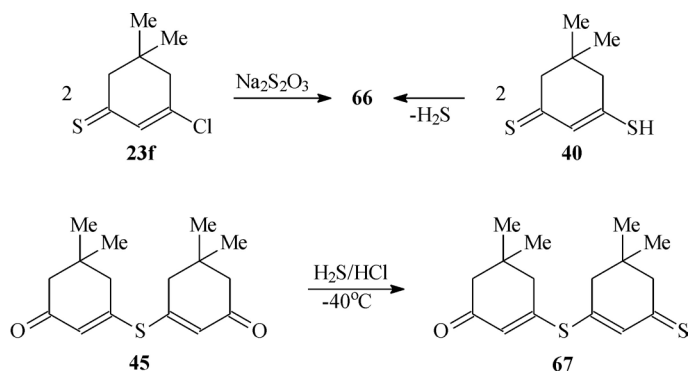

Figure 4.

Other pathways to the synthesis of bis(5,5-dimethyl-3-thioxocyclohex-1-enyl) sulfide (**66**) have been studied [41]. 5,5-Dimethyl-3-mercaptocyclohex-2-en-1-thione (**40**) in the temperature range -10 to -5°C without solvent or in chloroform solution undergoes autocondensation with evolution of hydrogen sulfide and formation of dithioxosulfide **66** (scheme 30). Also, treating 5,5-dimethyl-3-chlorocyclohex-2-en-1-thione (**23f**) with sodium thiosulfate in methanol at -20 to -30°C gives dithioxosulfide **66**, which was identified by TLC and IR spectroscopy (scheme 30) [41]. Bis(5,5-dimethyl-3-oxocyclohex-1-enyl) sulfide (**45**) reacts with H_2S in the presence of hydrogen chloride in methanol or a methanol-dioxane system at -30 to -40°C to form a complex mixture of labile sulfur-containing products. Analysis of the mixture using ^1H , ^{13}C NMR and two-dimensional NMR spectroscopy (HETCOR experiment) has revealed the presence of earlier unknown 3-oxo-3'-thio-bis(5,5-dimethylcyclohex-1-enyl) sulfide (**67**) (26%) (scheme 30) [41].

Some chemical transformations of dithioxosulfide **66** have been studied. The reactions of **66** with hydrazine, 1,1-dimethylhydrazine (1,1-DMH) and 2,4-dinitrophenylhydrazine (2,4-DNPH) have been performed with various ratios and concentrations of reagents in solution. The action of excess hydrazine on dithione **66** led to its dihydrazone **68**, whereas with 1,1-DMH and 2,4-DNPH under the same conditions monohydrazones **69**, **70** are formed (figure 5) [11, 39].



SCHEME 30

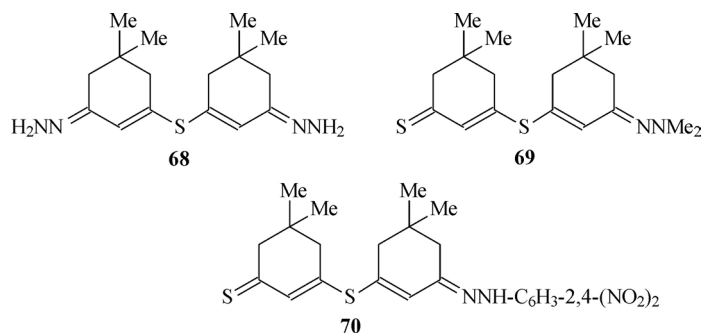
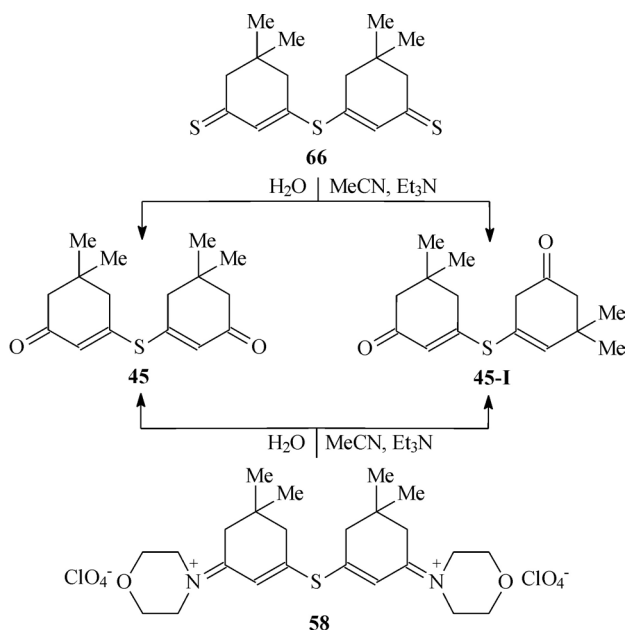

Figure 5.

Hydrolysis of dithione **66** in the system MeCN–Et₃N leads to a mixture of bis(5,5-dimethyl-3-oxocyclohex-1-enyl) sulfide (**45**) and its isomer **45-I**, which has the double bond at a different position in the cycle (scheme 31) [45].



SCHEME 31

The structure and ratio of isomers (**45:45-I** = 4:1) were established by ¹H and ¹³C NMR spectroscopy using multipulse experiments (APT) and two-dimensional NMR spectroscopy (HETCOR, NOESY) as well as quantitative approaches to the analysis of mixtures of organic compounds [46]. Independent evidence presented in support of the structure of isomer **45-I** is provided by the IR spectrum of its mixture with isomer **45**, in which there are three C=O bond stretching vibrations (1649, 1668, 1717 cm⁻¹). The same isomers (**45:45-I** = 8.7:1.3) are formed during hydrolysis of bis(5,5-dimethyl-1-morpholinocyclohex-2-en-3-yl) sulfide diperchlorate (**58**) under the above conditions (scheme 31) [45].

Notably, the previous formation of dioxosulfide **45** occurred in the reaction of 5,5-dimethyl-3-chlorocyclohex-2-en-1-one with Na₂S (yield 5% ; mp 176–177°C) [47]. The synthesis of dioxosulfide **45** by hydrolysis of bisimmonium salt **58** in acetonitrile in the presence of a catalytic amount of Et₃N enabled its preparation in 45% yield (mp 80–81°C) [45].

8.5 1,7-Dithio-substituted compounds as potential converters of solar energy

1,7-Dithio-substituted compounds are potentially prone to various intramolecular rearrangements. Using the RHF/6-31G** method in the self-concerted reactive field (SCRF) approximation, an investigation has been carried out of the thermodynamic stability, structural and electronic characteristics of thiabicyclic structures potentially able to be formed in bis(3-thioxo-1-phenylpropenyl) sulfide (**5**), bis(3-thioxo-1-propenyl) sulfide (**71**) and bis(5,5-dimethyl-3-thioxocyclohex-1-enyl) sulfide (**66**) during photo-induced reactions [48].

Energy is accumulated in thiabicyclic structures due to the formation of metastable highly strained condensed systems containing thiirane and cyclobutane cycles (scheme 32).

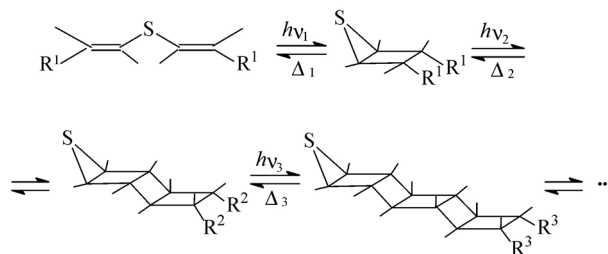
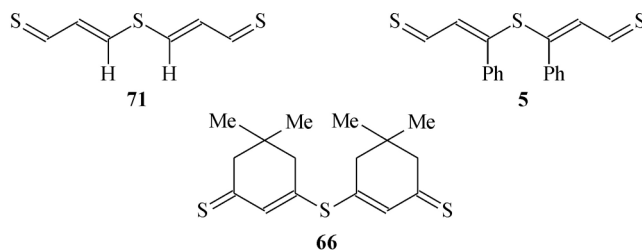

SCHEME 32

The heats of dark isomeric transformation from thiabicyclic into acyclic structures vary from 50 to 250 kcal mol⁻¹. Energies of activation of thermal transitions to the acyclic states are from 90 to 310 kcal mol⁻¹. Taking into account the effect of medium polarity in increasing the reaction heat and decreasing the energies of activation, energy parameters of the transition from thiabicyclic to acyclic structures meet the requirements imposed on solar energy cells. Thus, compounds containing an S=C-C=C-S-C=C-C=S structural fragment are proposed as initial materials in designing effective solar energy converters [48]. The search for compounds to be used as solar energy transformers is one of the worldwide approaches to the preparation of ecological energy sources [49].

References

- [1] Liebscher, J. and Hartmann, H., 1979, *Synthesis*, 241.
- [2] Usov, V. A., Timokhina, L. V. and Voronkov, M. G., 1986, *Usp. Khim.*, **55**, 1761.
- [3] Timokhina, L. V., Tsetlin, Ya. S., Tsetlina, E. O., Usov, V. A. and Voronkov, M. G., 1978, *Zh. Org. Khim.*, **14**, 666.
- [4] Timokhina, L. V., Usov, V. A. and Voronkov, M. G., 1978, *Zh. Org. Khim.*, **14**, 2226.
- [5] Usov, V. A., Timokhina, L. V. and Voronkov, M. G., 1980, *Zh. Org. Khim.*, **16**, 226.
- [6] Usov, V. A., Timokhina, L. V., Shagun, V. A., Sidorkin, V. F. and Voronkov, M. G., 1981, *Zh. Org. Khim.*, **17**, 1816.

- [7] Timokhina, L. V., Usov, V. A., Tsetlin, Ya. S., Tsetlina, E. O. and Voronkov, M. G., 1979, *Zh. Org. Khim.*, **15**, 82.
- [8] Usov, V. A. and Voronkov, M. G., 1982, *Sulfur Rep.*, **2**, 39.
- [9] Timokhina, L. V., Dolenko, E. V., Usov, V. A., Toryashinova, D.-S. D., Protasova, L. E. and Voronkov, M. G., 1996, *Khim. Geterosikl. Soedin.*, 493.
- [10] Timokhina, L. V., Usov, V. A., Voronkov, M. G., Kozyreva, O. B., Panova, G. M. and Yashchenko, M. P., 1996, *Zh. Org. Khim.*, **32**, 1879.
- [11] Timokhina, L. V., 2002, D.Sc. Dissertation Thesis, A. E. Favorsky Irkutsk Institute of Chemistry, Siberian Division Russian Academy of Sciences.
- [12] Usov, V. A., Timokhina, L. V. and Voronkov, M. G., 1992, *Sulfur Rep.*, **12**, 95.
- [13] Shagun, V. A., Timokhina, L. V. and Panova, G. M., 1999, *Izv. Akad. Nauk Ser. Khim.*, 2255.
- [14] Shagun, V. A., Timokhina, L. V. and Panova, G. M., 1997, *Izv. Akad. Nauk Ser. Khim.*, 1273.
- [15] Usov, V. A., Timokhina, L. V. and Voronkov, M. G., 1990, *Usp. Khim.*, **59**, 649.
- [16] Okuma, K., 2002, *Sulfur Rep.*, **23**, 209.
- [17] McKenzie, S. and Reid, D. H., 1966, *Chem. Commun.*, 401.
- [18] Dolenko, E. V., Usov, V. A., Timokhina, L. V., Usova, T. L., Protasova, L. E. and Voronkov, M. G., 1987, *Khim. Geterosikl. Soedin.*, 1694.
- [19] Toryashinova, D.-S. D., Shagun, V. A., Timokhina, L. V. and Voronkov, M. G., 1996, Abstracts, 17th Int. Symp. Org. Chem. of Sulfur, Tsukuba, Japan, p. 178.
- [20] Timokhina, L. V., Dolenko, E. V., Kozyreva, O. B., Panova, G. M., Yashchenko, M. P., Toryashinova, D.-S. D. and Voronkov, M. G., 1998, *Zh. Org. Khim.*, **34**, 633.
- [21] Duus, F., In: Barton, D. and Ollis, W. D. (Eds.), 1983, *Obshchaya Organicheskaya Khimiya (Moskva: Khimiya)*, Vol. 5, p. 585.
- [22] Timokhina, L. V., Panova, G. M., Yashchenko, M. P. and Voronkov, M. G., 1999, *Zh. Org. Khim.*, **35**, 1538.
- [23] Timokhina, L. V., Usov, V. A. and Voronkov, M. G., 1984, *Zh. Org. Khim.*, **20**, 1351.
- [24] Timokhina, L. V. and Usov, V. A., 1980, *Zh. Org. Khim.*, **16**, 1553.
- [25] Usov, V. A., Dorofeev, I. A., Timokhina, L. V. and Voronkov, M. G., 1987, *Zh. Org. Khim.*, **23**, 1566.
- [26] Usov, V. A., Dorofeev, I. A., Timokhina, L. V. and Voronkov, M. G., 1988, *Zh. Org. Khim.*, **24**, 666.
- [27] Usov, V. A., Dorofeev, I. A., Usova, T. L., Timokhina, L. V. and Voronkov, M. G., 1990, *Zh. Org. Khim.*, **26**, 359.
- [28] Korchevin, N. A., Usov, V. A., Oparina, L. A., Dorofeev, I. A., Tsetlin, Ya. S. and Voronkov, M. G., 1980, *Zh. Org. Khim.*, **16**, 1842.
- [29] Usov, V. A., Timokhina, L. V., Turchaninov, V. K., Taryashinova, D. S. D. and Voronkov, M. G., 1987, *Zh. Org. Khim.*, **23**, 1221.
- [30] Usov, V. A., Timokhina, L. V., Lavlinskaya, L. I. and Voronkov, M. G., 1979, *Zh. Org. Khim.*, **15**, 2598.
- [31] Timokhina, L. V., Usova, T. L., Usov, V. A. and Voronkov, M. G., 1981, *Khim. Geterosikl. Soedin.*, 993.
- [32] Timokhina, L. V., Panova, G. M. and Voronkov, M. G., 1998, *Khim. Geterosikl. Soedin.*, 843.
- [33] Timokhina, L. V., Usov, V. A., Lavlinskaya, L. I. and Voronkov, M. G., 1985, *Zh. Org. Khim.*, **21**, 119.
- [34] Liler, M., 1975, *Adv. Phys. Org. Chem.*, **11**, 267.
- [35] Hickmott, P. W., 1982, *Tetrahedron*, **38**, 1975.
- [36] Usov, V. A., Kuznetsova, E. E., Timokhina, L. V., Malkova, T. I., Leont'eva, A. G. and Voronkov, M. G., 2002, *Izobreteniya. Poleznye Modeli*, **12**, 338.
- [37] Usov, V. A., Timokhina, L. V., Usova, T. L. and Voronkov, M. G., 1981, *Zh. Org. Khim.*, **17**, 1327.
- [38] (a) Petriashvili, K. A., Usov, V. A. and Voronkov, M. G., 1986, *Zh. Org. Khim.*, **22**, 569; (b) Steliou, K., Salama, P., Brodeur, D. and Gareau, Y., 1987, *J. Am. Chem. Soc.*, **109**, 926; (c) Oae, Sh., 1988, *Rev. Heteroatom. Chem.*, **1**; (d) Voronkov, M. G., Usov, V. A., Shagun, L. G. and Usova, T. L., 1988, *Zh. Org. Khim.*, **24**, 2464; (e) Kato, S., 1997, *Phosphorus, Sulfur Silicon Relat. Elem.*, **120&121**, 213.
- [39] Timokhina, L. V., Panova, G. M., Toryashinova, D.-S. D., Albanov, A. I., Sokol'nikova, O. V. and Voronkov, M. G., 1999, *Zh. Org. Khim.*, **35**, 1436.
- [40] Timokhina, L. V., Sokol'nikova, O. V., Panova, G. M., Toryashinova, D.-S. D. and Voronkov, M. G., 2000, *Zh. Org. Khim.*, **36**, 1714.
- [41] Timokhina, L. V., Panova, G. M., Kanitskaya, L. V., Sokol'nikova, O. V., Toryashinova, D.-S. D. and Voronkov, M. G., 2001, *Zh. Org. Khim.*, **37**, 1725.
- [42] Timokhina, L. V., Usov, V. A., Voronkov, M. G., Kozyreva, O. B., Panova, G. M. and Yashchenko, M. P., 1995, *Zh. Org. Khim.*, **31**, 1092.
- [43] Timokhina, L. V., Bel'skii, V. K., Toryashinova, D.-S. D., Panova, G. M., Kozyreva, O. B., Yashchenko, M. P. and Voronkov, M. G., 1997, *Zh. Org. Khim.*, **33**, 1566.

- [44] Kanitskaya, L. V., Timokhina, L. V., Panova, G. M., Fedorov, S. V. and Aksamentova, T. N., 2002, *Zh. Obshch. Khim.*, **72**, 78.
- [45] Timokhina, L. V., Panova, G. M., Kanitskaya, L. V., Toryashinova, D.-S. D., Sokol'nikova, O. V., Fedorov, S. V. and Voronkov, M. G., 2001, *Zh. Org. Khim.*, **37**, 1400.
- [46] Kalabin, G. A., Kanitskaya, L. V. and Kushnarev, D. F., 2000, *Kolichestvennaya Spektroskopiya NMR Prirodnogo Organicheskogo Syr'ya i Produktov ego Pererabotki* (Moskva: Khimiya), p. 408.
- [47] Dalgaard, L. and Lawesson, S.-O., 1974, *Acta Chem. Scand., B*, **28**, 1077.
- [48] Shagun, V. A., Timokhina, L. V., Panova, G. M. and Frolov, Yu. L., 2003, *Zh. Obshch. Khim.*, **73**, 761.
- [49] Flid, V. R., 1999, *Soros Educ. J.*, **9**(46), 33.

